

## LSS-14P INSTRUCTIONS AND PARTS LIST



The LSS-14P is a quiet, clean 14" slab saw in a compact bench-top design. Equipped with a fast, powerful screw-feed and a 5-1/2" capacity vise. Properly set up, operated and maintained, the Panther will cut rock at twice the speed of standard screw-feed saws. Oil coolant required.

- 14" Blade for Larger Cuts
- Bench-Top Design
- Fast Power Screw-Feed
- Sturdy Welded Steel Frame Won't Crack or Warp
- Built-in Blade Sharpener
- Hinged Hood with Tempered Glass Window

## SETUP

- Check to make sure you have received the following parts:
    - (1) LSS14-P Saw
    - (1) Belt Guard with mounting screws
    - (1) Drive Belt
    - (1) Accessory Package Containing:
      - (4) Motor Mounting Bolts with Nuts and Washers
      - (2) Motor Mount Attachment Screws
      - (2) Adjusting Bolts with Nuts and Caps
      - (1) 3" x 5/8" Motor Pulley
    - (1) Operators Manual and Warranty Card
    - (1) 14" Diamond Blade
    - (1) 1/2 HP Drive Motor
- Note: Motor for this unit is shipped separately.

**IMPORTANT**  
Read the following instructions before assembly or use. Failure to follow instructions can result in damage to the machine or injury to the operator.

- Remove the saw from its packing and place on a sturdy, flat, level surface.

## MOTOR INSTALLATION

- Secure motor to motor mount with bolts provided.
- Install adjustment bolts in motor mount as shown and attach motor to saw frame.
- Place motor pulley on the motor shaft. Tighten set screw securely.
- Install belt and adjust motor to obtain correct belt alignment and tension.  
Do not over tighten the belt as this can lead to excessive noise and premature bearing wear.

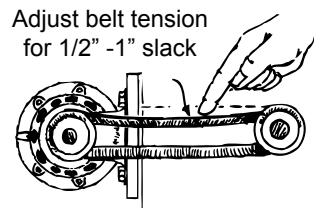
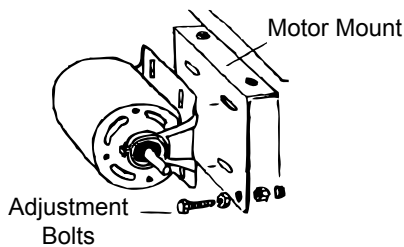

## BELT GUARD INSTALLATION

- Place belt guard over the belt, motor pulley, and frame.
- Install the two mounting screws, tighten securely.

## SLAB CATCHER

- Loosen hold-down screws and adjust slab catcher to clear blade by 1/8".

## BLADE SHARPENER

- Loosen set screw on blade sharpener handle.
- Rotate handle until it is straight up and tighten set screw securely.

Install Blade & Outer Flange, Tighten Arbor Nut securely.

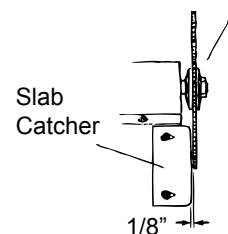

## ELECTRICAL CONNECTION

- Make sure all Switches on the Motor and Control Box are in the OFF position
- Make sure the hood is closed.
- Plug the Motor Cord into the outlet on the Control Box.
- Plug the Saw Power Cord into a grounded outlet

## COOLANT

We recommend LORTONE Cutting Oil #086-010 for optimal results.

- Use a neutral petroleum base oil with a high flash point and no additives.
- Add approximately 2 gallons of coolant until the bottom 1/4"-1/2" of the blade is covered.

### CAUTION

**DO NOT** run saw without proper coolant.  
**DO NOT** use Kerosene or other flammable solvents.  
**DO NOT** use water or water soluble oils.  
Failure to follow these instructions can result in damage to machine or serious injury to operator.  
Use of these coolants will void the warranty.

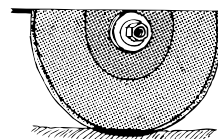

Coolant 1/4"-1/2" on Blade

## BLADE CARE & DRESSING

- Clamp a Blade Dressing Stick in the vise. With the hood closed and the saw running, lightly pull the blade sharpener handle forward. Repeat as needed.
- Dress the blade frequently. Dull or glazed blades will quickly dish or warp.  
*Note:* Dished or warped blades are not covered under warranty.
- **YOU MUST DRESS THE BLADE PRIOR TO INITIAL USE.**  
This removes the protective paint from the cutting edge of the blade.

## OPERATION

- Make sure all Switches on Control Box are in the "OFF" position (toward saw) before opening the hood.
- Clamp material securely in vise. Check for looseness of material and re-tighten if necessary.
- Adjust cross feed and hand tighten the carriage lock screw #488-056. See Fig A.  
Check to be sure that material will clear the arbor shaft cover and the blade flanges.
- To release carriage, pull half nut lever toward control box. Slide the carriage to desired position and release the half nut lever. Make sure the lever is fully engaged.
- Adjust shutoff chain #447-001 for desired length of cut.

### To Start Saw:

**Note:** The "Power" switch operates the motor and supplies power to the "Feed" switch. The "Feed" switch operates the feed motor only and will not work with the "Power" switch in the off position.

- Close hood and make sure both switches are in the "OFF" position.
- Turn the "Power" switch to "ON" position to start blade rotation.
- To start power feed, turn "Feed" switch to "ON" position.

### While Cutting: **IMPORTANT-** DO NOT LEAVE SAW UNATTENDED

- Listen for changes in operating noise. Sudden changes can indicate damaged material or blade.
- Over-heating of the main motor can result in tripping of the safety overload protector.

**Note:** Tripping the safety overload protector does not shut off the power feed. To prevent blade & saw damage, IMMEDIATELY turn off both the "Power" & "Feed" switches. Inspect the machine and blade for damage and correct any problems before continuing. When cool, press the red reset button on the drive motor to reset the protector.

### At End of Cut:

- Push both switches toward saw to "OFF" position before opening the hood.
- Remove the cut slab. Inspect the remaining material to make sure it is secure in the vise.
- Loosen carriage lock screw and advance the carriage by turning the cross-feed wheel.  
Each turn advances the cross-feed carriage approximately 1/16 inch (.062).

### CAUTION

Do not operate saw with Hood open.  
Turn off both switches and unplug saw prior to opening hood.  
Failure to follow these instructions can result in serious injury.

## CLEANING MAINTENANCE

- The saw should be cleaned periodically when sediment builds up to a depth of 1/4".
- Unbolt the saw case from the coolant pan and lift out the case.
- Empty the coolant pan and wipe sludge from the case and power feed screw.
- Re-install case in coolant pan, attach bolts, and add clean and/or filtered oil.

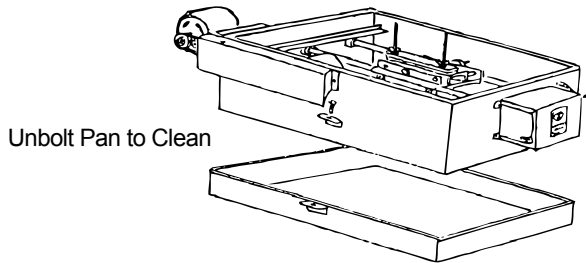

Pour Out Used Oil &  
Dispose of Properly.

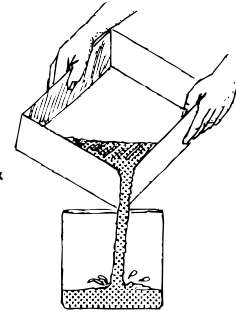

## Model LSS-14P Parts List

Item	Description	Item	Description
119-001	Cross Feed Handle Assy.	058-107	Half Nut
053-001	Feed Rod	481-057	Arbor Nut
053-004	Bracket, Bearing	058-028	3" Flange
053-010	Vise Top Plate	215-003	Set Collar
053-011	Vise Top Pad	215-009	Set Collar
053-012	Slab Catcher	215-002	Carriage Collar
053-013	Arbor Cover	200-005	Carriage Bearing
053-014	Motor Mount	200-006	Arbor Bearing
053-016	Carriage Way	201-012	Feed Rod Bearing
053-047	Window Key Rubber	203-001	Bearing
053-048	Window Rubber Seal	204-001	Bearing Strap
053-109	Control Box (Box Only)	205-010	Felt Washer
053-106	Belt Guard	206-031	Retaining Ring
054-007	Cross Feed Bolt	210-041	Belt (4L370)
481-081	Wing Nut	211-019	Motor Pulley (3"x5/8")
058-108	Arbor Shaft with fixed Flange	211-031	Arbor Pulley (4"x3/4")
058-005	Channel, Carriage	213-002	Spring
058-006	Shaft, Cross Feed	213-014	Extension Spring
053-009	Vise Bottom Plate	213-016	Compression Spring
058-010	Spring Arm	215-005	Set Collar
058-014	Vise Handle	260-001	Window
058-016	Sharpener Shaft	290-001	Hood Handle
058-017	Vise Bottom Pad	290-012	Hood Brace
058-020	Feed Rod Coupling	290-016	Knob
058-022	Power Feed Support	301-060	Power Feed Motor, 110V
058-030	3" Sharpener Vise Bolt	301-061	Power Feed Motor, 220V (International)
058-032	3-1/2" Sharpener Vise Bolt	304-012	Switch
058-034	Sharpener Vise Bottom	304-013	Switch Hex Nut
058-036	Sharpener Vise Top	304-014	Switch Lock Washer (not shown)
058-100	Hood	305-002	Receptacle
058-101	Case	320-004	Strain Relief
058-102	Vise Carriage (Frame Only)	350-002	Cord
058-104	Coolant Pan	447-002	Shutoff Chain (21" long)
058-126	Complete Control Box	488-056	Carriage Lock Screw
209-003	Foot	566-012	Blade Dressing Stick (3-pk.)
		290-016	Handle Knob (for blade sharpener)

**Vise Carriage**  
Fig. A

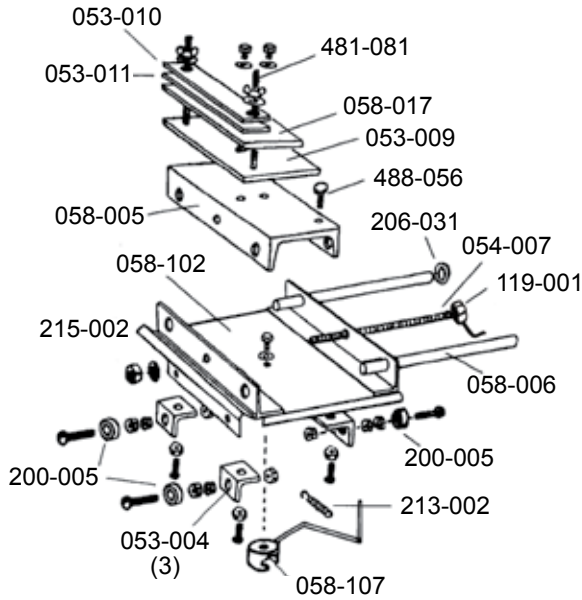

**Arbor Shaft**  
Fig. B

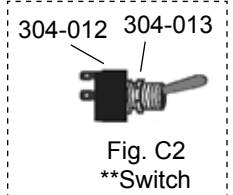
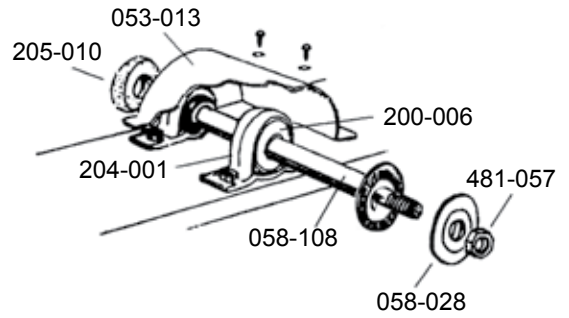

**Gear Box**  
Fig. C

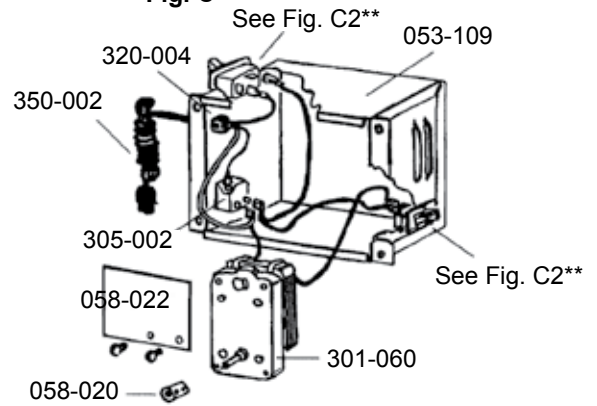

**Blade Sharpener**  
Fig. D

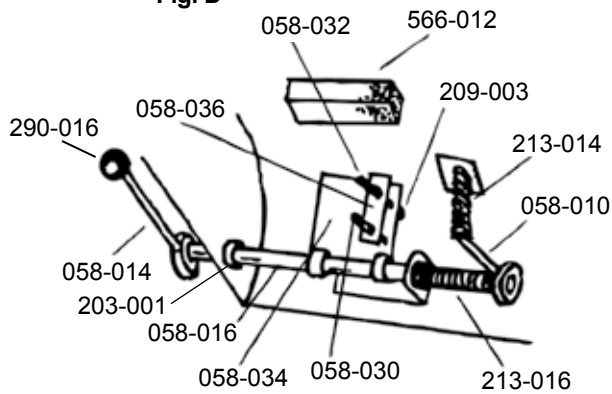

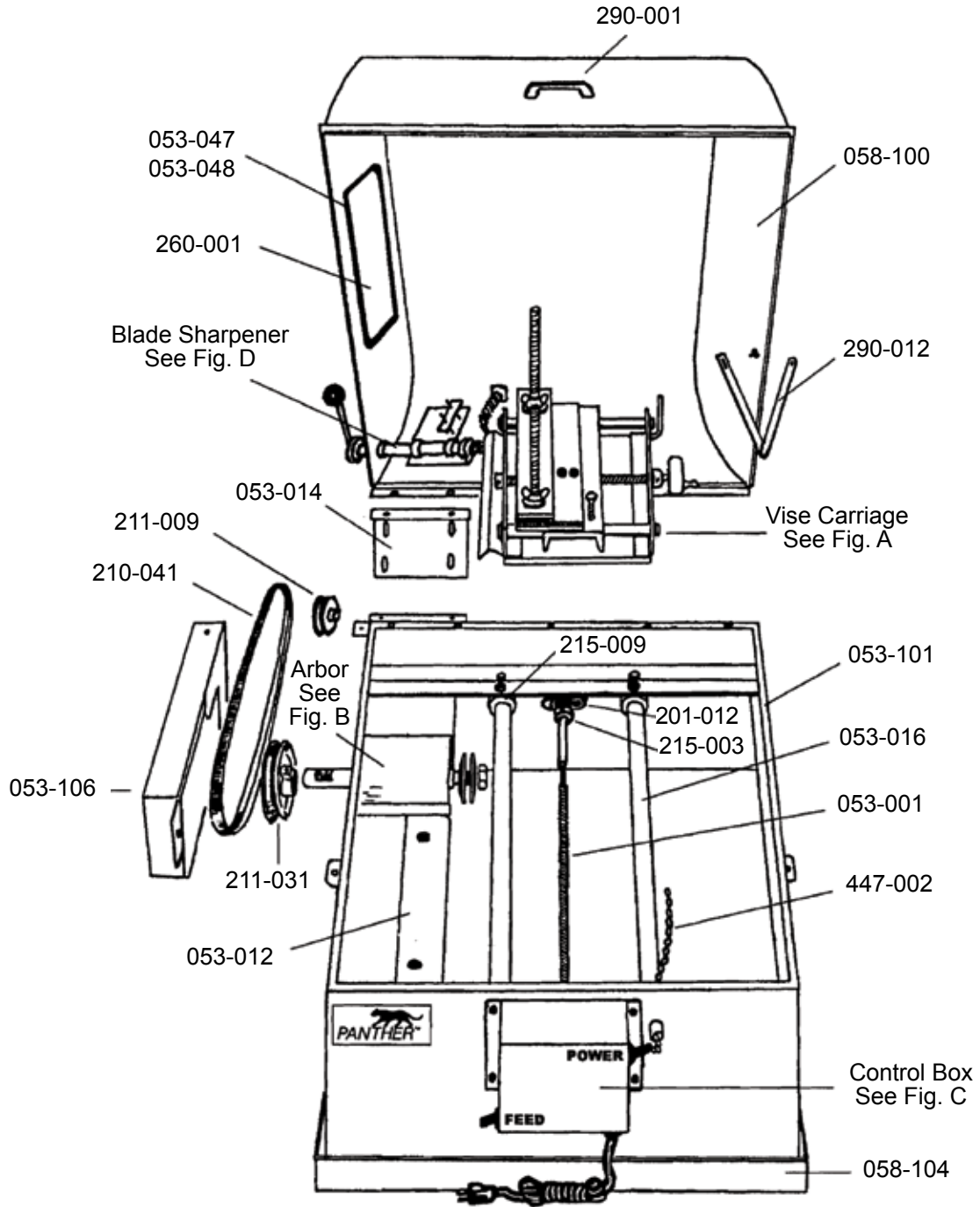

# **CAUTION !!**

**Failure to follow these instructions  
may result in injury to the operator  
and damage to the machine.**

***FOR PROPER OPERATION USE ONLY  
5-10 wt. PETROLEUM OIL,  
NON-DETERGENT TYPE,  
WITH A HIGH FLASH POINT***

**DO NOT USE water, water-soluble oil,  
solvents, fuels, anti-freeze or vegetable oil.**

**Use of these or other materials will result in  
substandard performance and damage to  
the machine is not covered under warranty.**

**We suggest LORTONE Cutting Oil  
#086-010**

# **CAUTION !!**