

6" TRIM SAW PACKAGE

INSTRUCTIONS AND PARTS LIST

(including 6" Trim Saw Basic)



Rugged Steel Frame • Compact Size • Accepts 6" Diamond Blade

LORTONE Trim Saws are high quality saws for trimming slabs to finished configuration. Cuts cleanly and easily with excellent visibility. For use with oil or water coolants. Follow these basic operating and care instructions to help keep your saw in optimal running condition.

SETTING UP YOUR MACHINE

- Check to make sure you have the following parts:

(1) Frame with Bearings	(1) Blade Guard
(1) Splash Shield	(1) Belt Guard
(1) Operators Manual	(1) Warranty Card

If any parts are missing, please contact your dealers or the factory immediately.

IMPORTANT!!!

Read the following instructions before assembly or use of your machine. Failure to follow instructions could result in damage to the machine or injury to operator.

MOTOR INSTALLATION

Note: Either a 1/4 hp or 1/3 hp, 1725 RPM motor is recommended for proper operation. Motor pulley should be 2" to 2 1/2" diameter. Drive belt should be selected to match desired motor mounting position.

- Make sure the saw and motor are secured to a base or work surface.
- Place motor pulley on the motor shaft and securely tighten the set screw on flat of motor shaft.
- Install belt and adjust motor to obtain correct belt tension. Do not overtighten the belt as this will lead to excessive noise and premature bearing wear. The belt should not deflect more than 1".

BLADE INSTALLATION

- Install 1st flange.
- Slide the Blade onto the Shaft.
- Slide the second flange next to the blade and tighten the arbor nut securely.



Fig. 1

OPERATION

- Fill the coolant tank with lapidary cutting oil until coolant covers approximately 1/4" of the blade rim (Fig. 2).

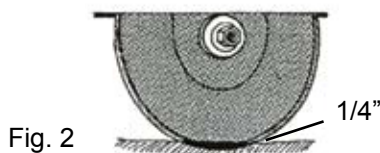

Fig. 2

CAUTION!!!

Do not operate without coolant. Injury to operator or damage to blade and machine may occur.

- Cut slowly using a straight forward motion (Fig. 3). Do not force stone into blade or apply side pressure.

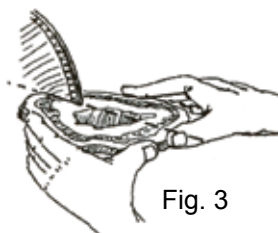

Fig. 3

MAINTENANCE

- Check belt for wear and proper tension. Refer to Motor Installation.
- Check blade for wear and correct alignment.
- Keep blade sharpened by periodically making a cut into a dressing stick or an old medium grit aluminum oxide or silicon carbide grinding wheel. This helps to expose fresh diamond crystals. (Fig 4). Cascade™ dressing sticks #566-012 are recommended.
- Maintain a proper coolant level.
- Change the coolant frequently or when it becomes dirty (Fig. 5). Drain after use.



Fig. 4

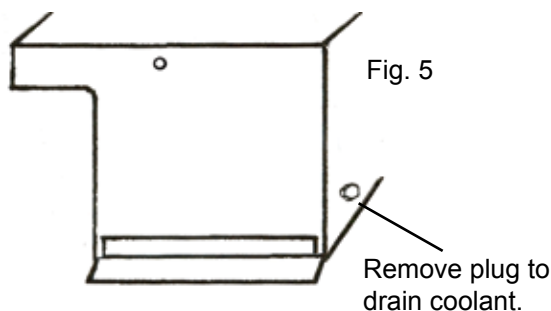
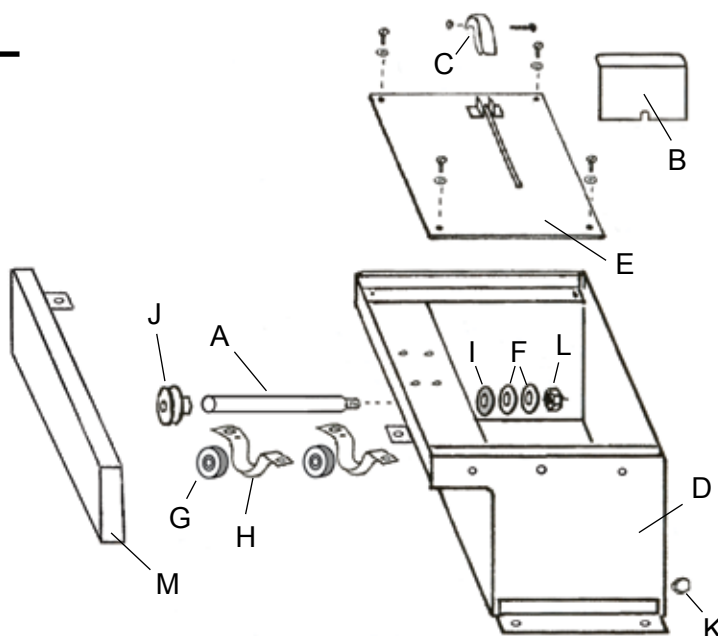

Fig. 5

Remove plug to drain coolant.

PARTS LIST 6" TRIM SAW

Part No.	Description
A 051-201	Arbor Shaft
B 051-206	Splash Shield
C 051-205	Blade Guard
D 051-200	Saw Tank Assembly
E 051-204	Trim Table Assembly
F 101-001	Flange, 1-1/2" x 1/2"
G 200-002	Bearing (2 required)
H 204-002	Bearing Strap (2 required)
I 205-001	Felt Washer
J 211-006	Arbor Pulley, 2" x 5/8"
K 216-001	Drain Plug
L 481-024	Hex Nut, 1/2-20
M 051-202	6" Belt Guard Assy



Included with Complete Package (not shown)

211-009	2 1/4" x 1/2" Motor pulley
210-023	4L-250 (AX23) Belt
300-022	1/3 hp motor
522-039	6" Blade
051-203	Base Assy